

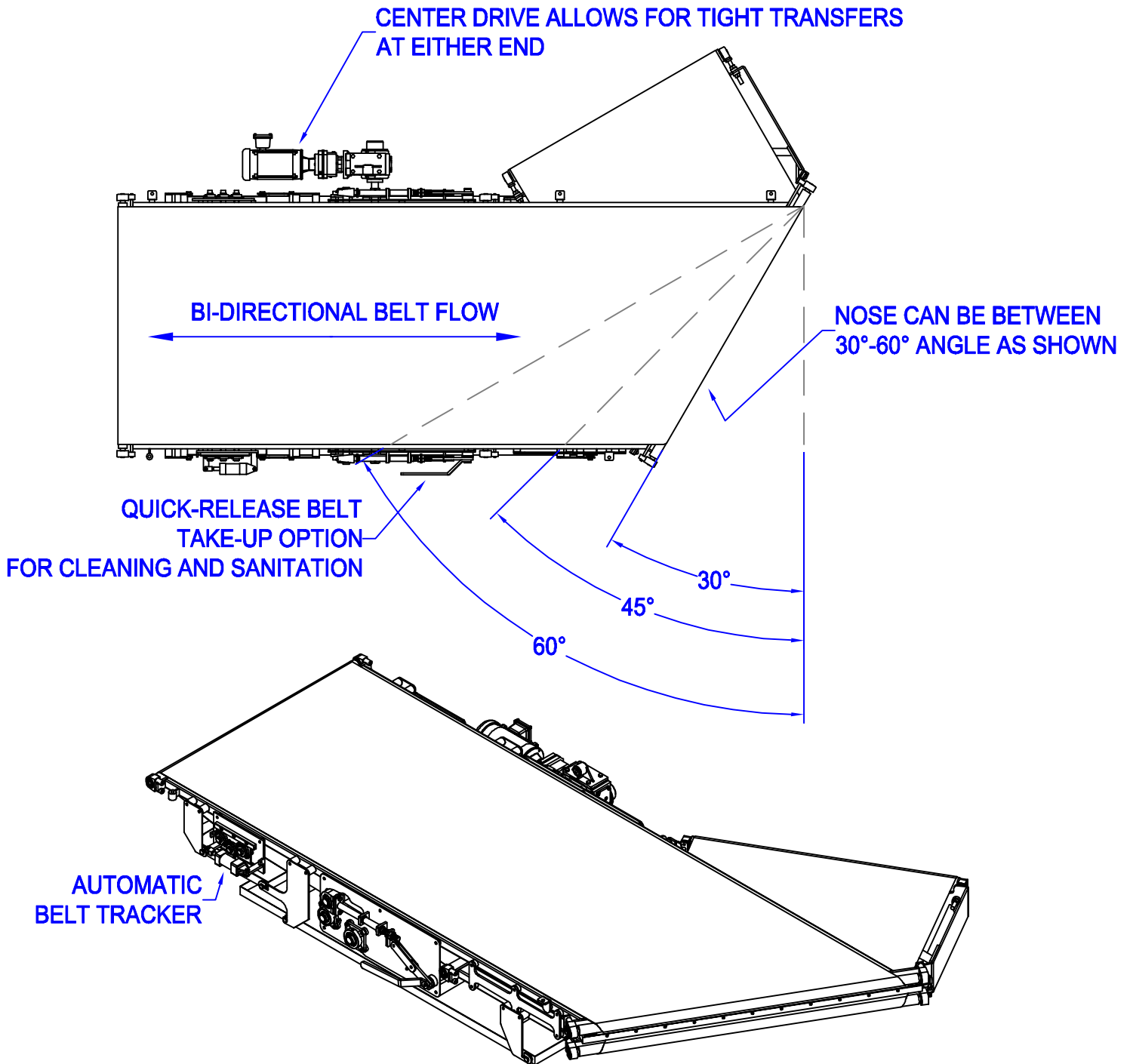

# MERGE CONVEYOR



**\*\*STAINLESS STEEL CONSTRUCTION\*\***  
**\*\*CAN BE FLOOR MOUNTED OR HUNG\*\***

# KOFAB MERGE CONVEYOR

## POSSIBLE APPLICATIONS:

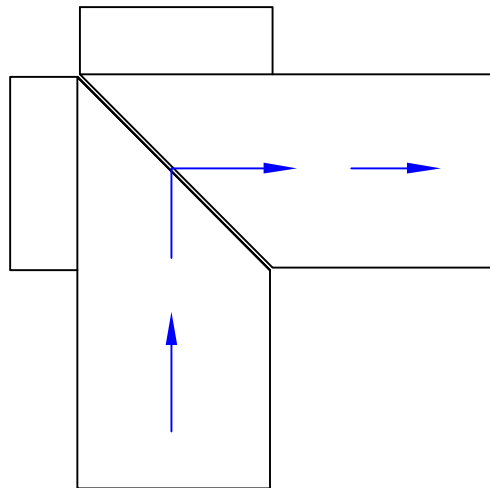

TWO 45° CONVEYORS CREATE  
CORNER MITER TRANSFER

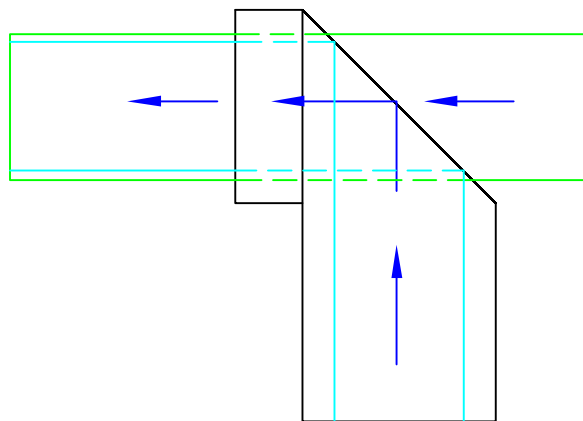

DOUGH SHEETER 90° TRANSFER

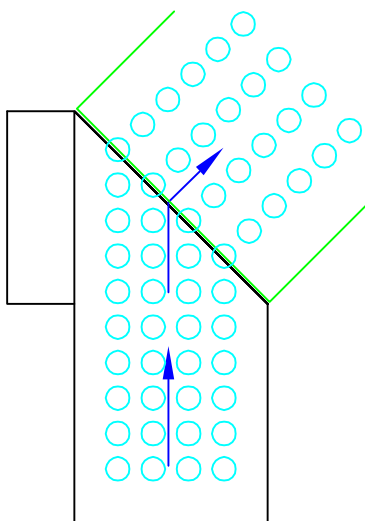

DIVERGE TRANSFER

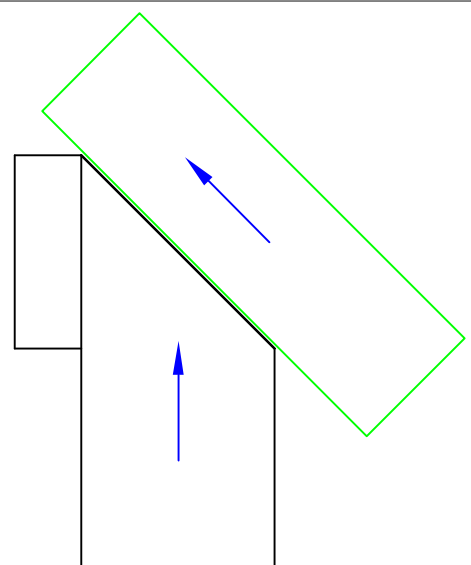

TRADITIONAL MERGE